

A DUCT LINER DETAIL
SCALE: NONE

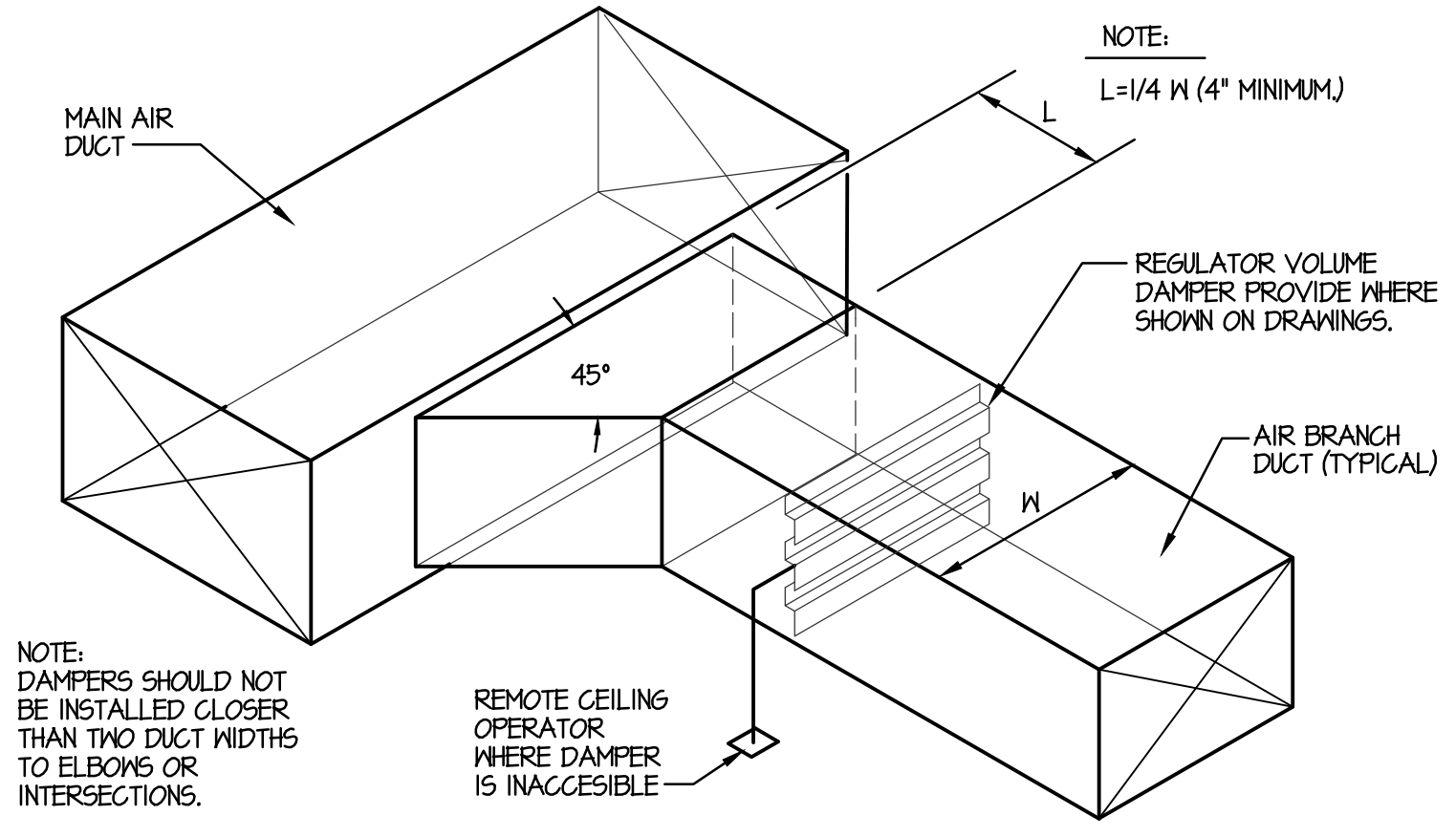

**B SUPPLY OR RETURN AIR DUCT
BRANCH CONNECTION DETAIL**
SCALE: NONE

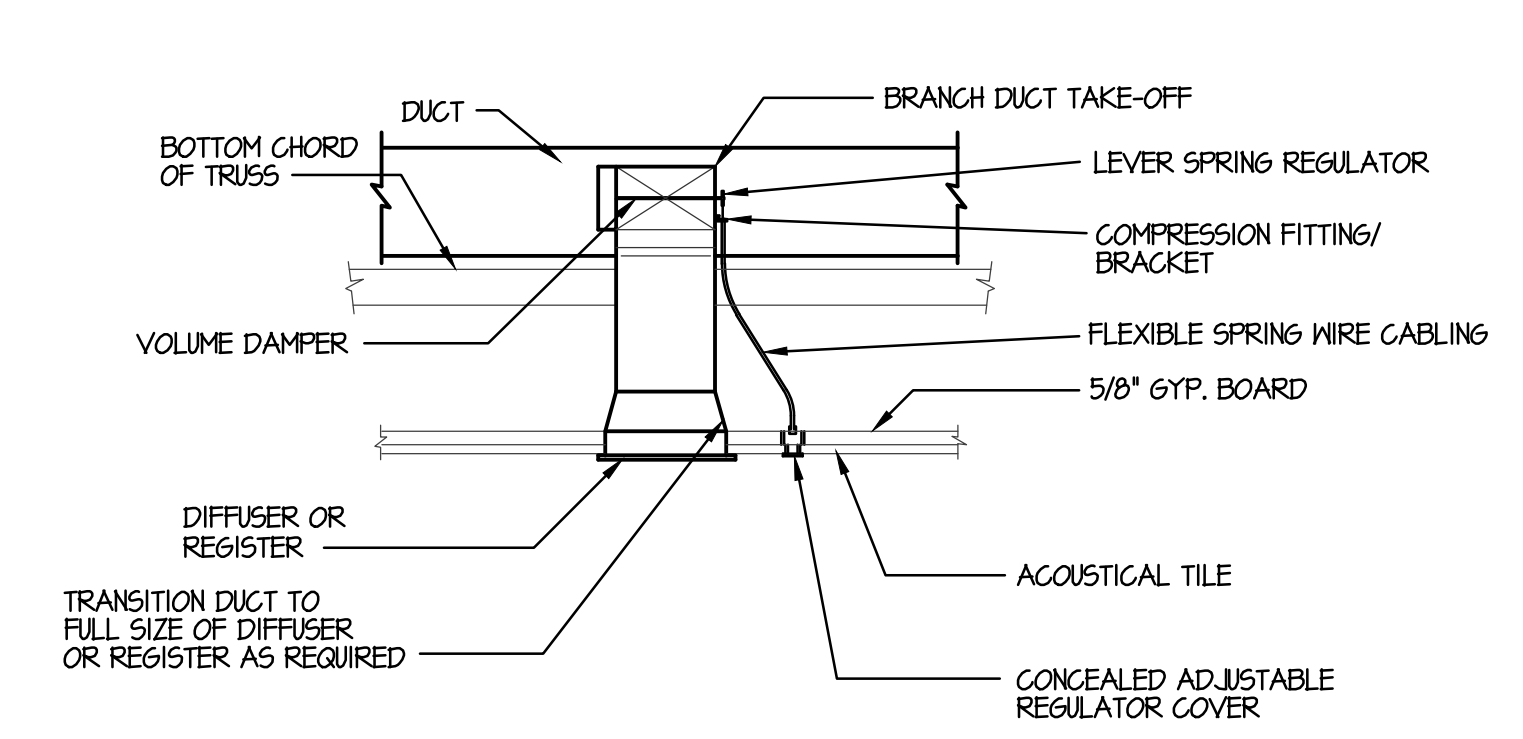

C TYPICAL REMOTE OPERATED DAMPER
NOT TO SCALE

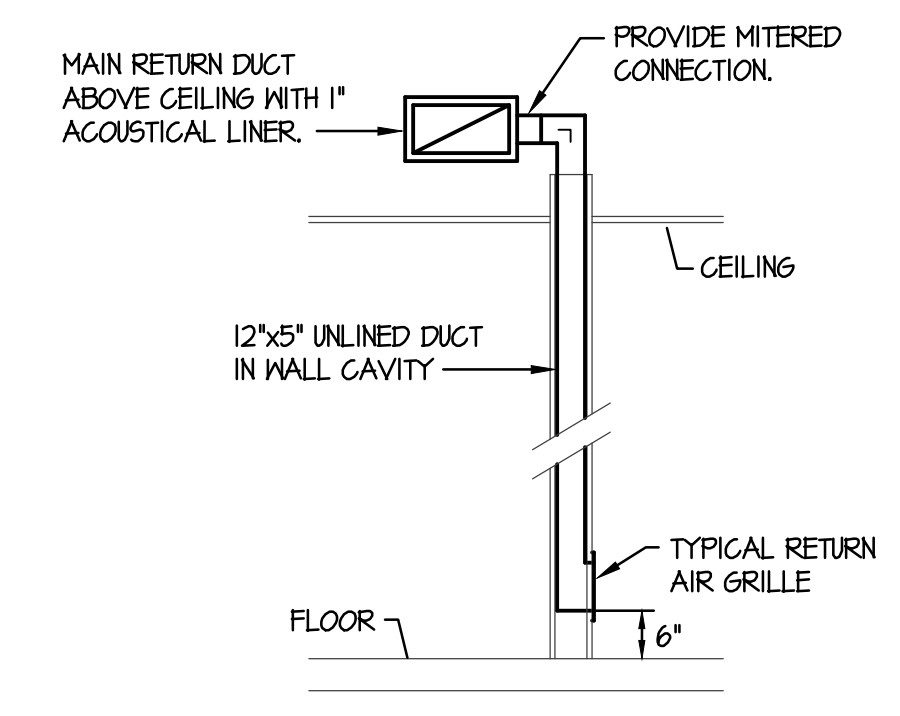

D RETURN AIR GRILLE DETAIL
NO SCALE

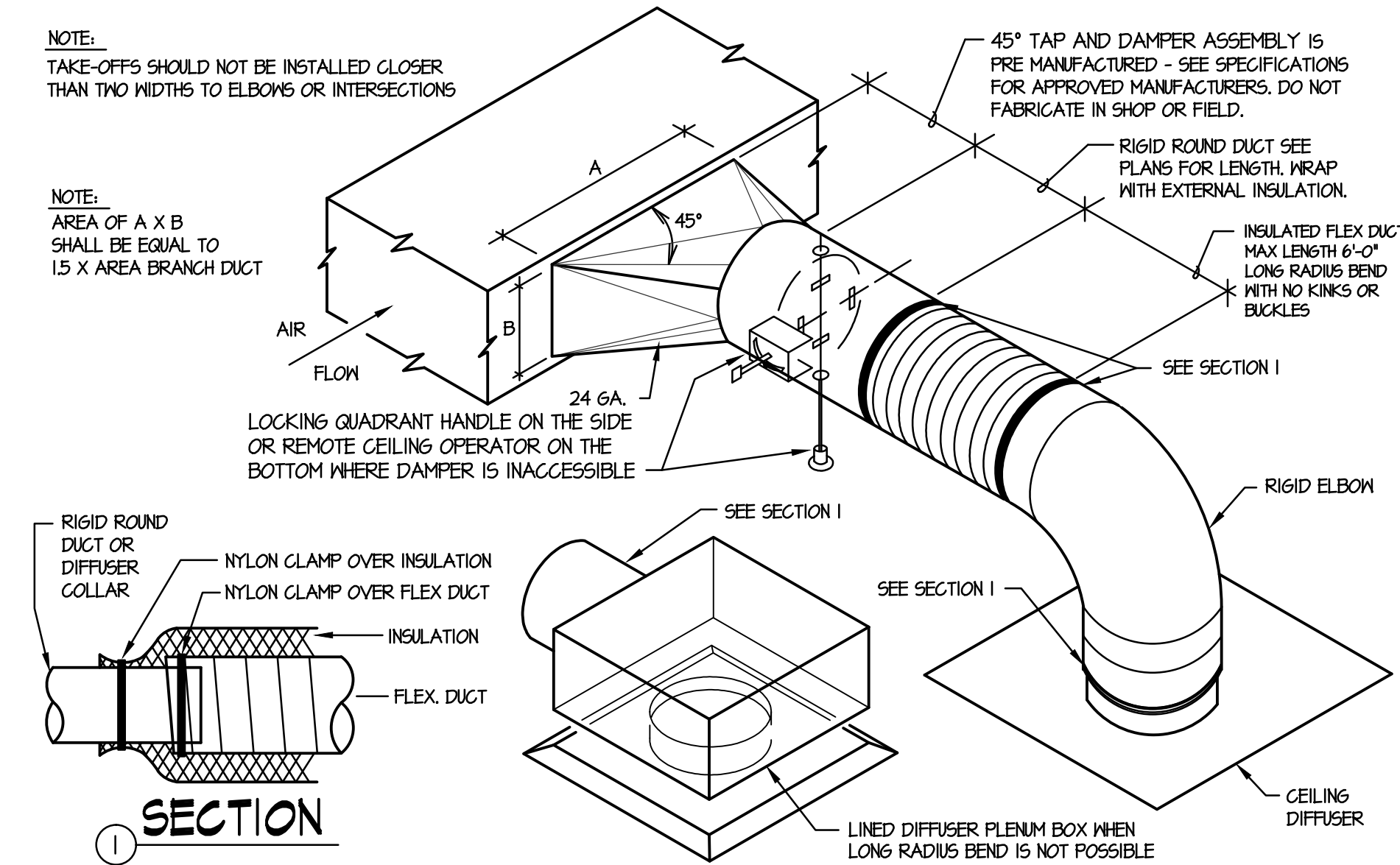

E SQUARE TO ROUND TAKE-OFF DETAILS
NO SCALE

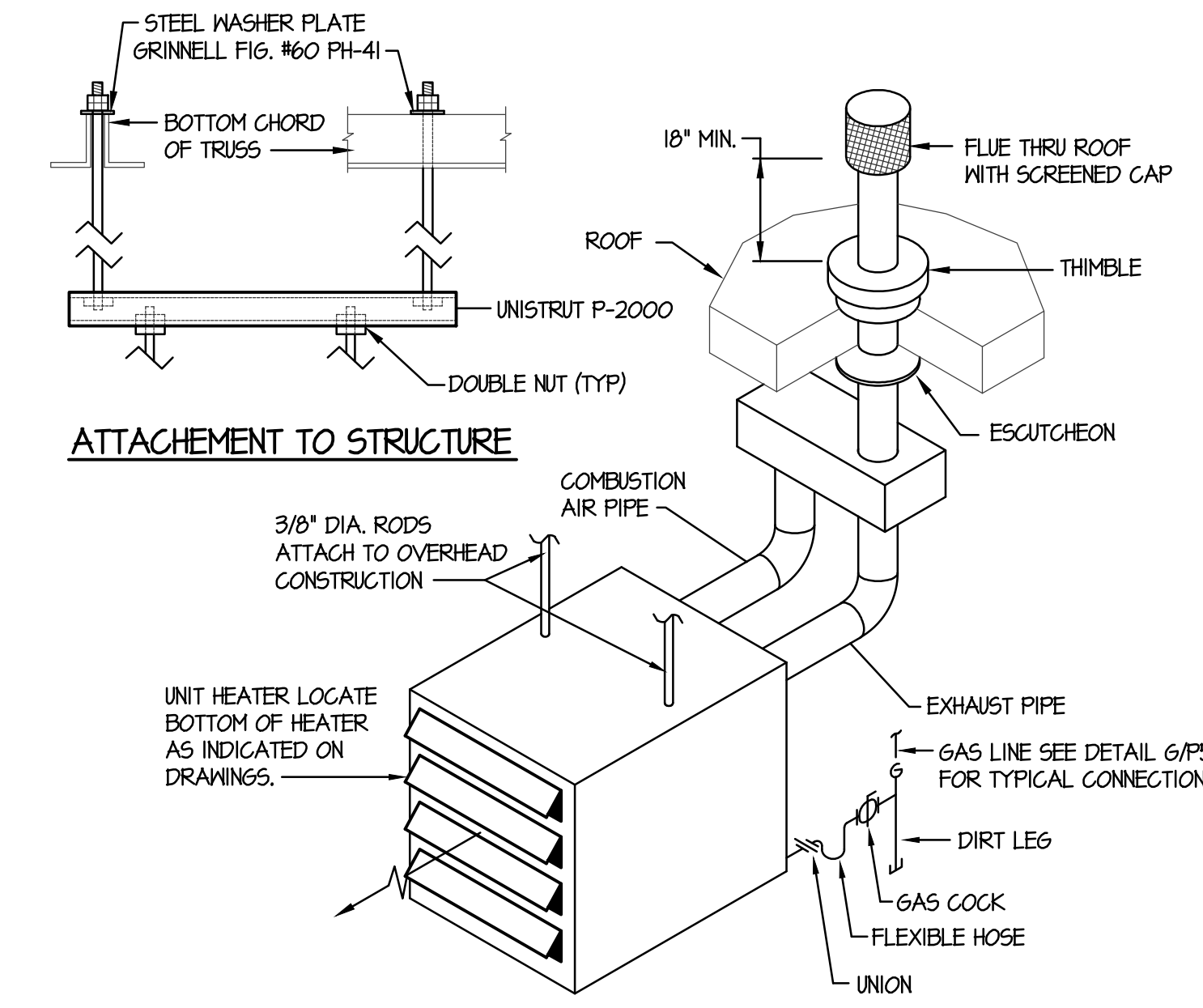

F SEPARATED COMBUSTION GAS FIRED UNIT HEATER DETAIL
NO SCALE

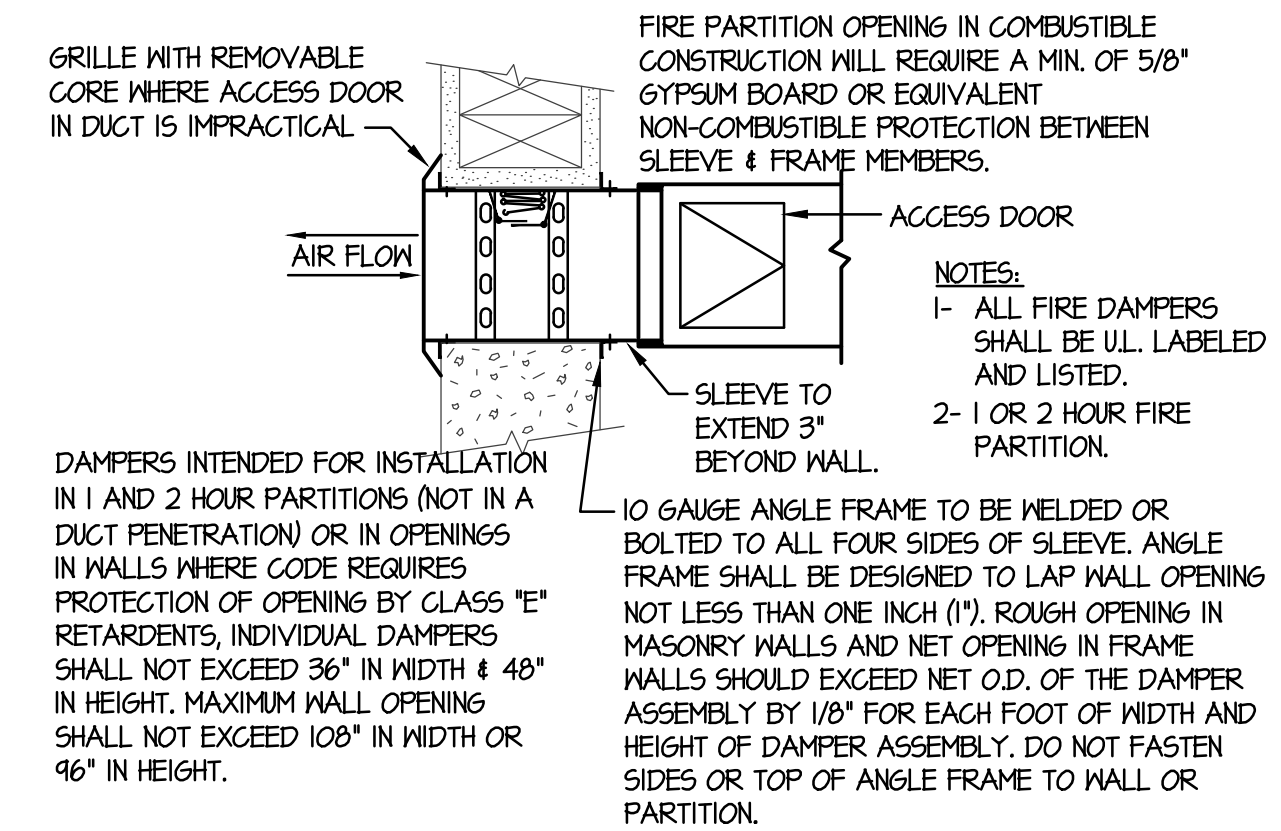

H SIDEWALL FIRE DAMPER DETAIL
NO SCALE

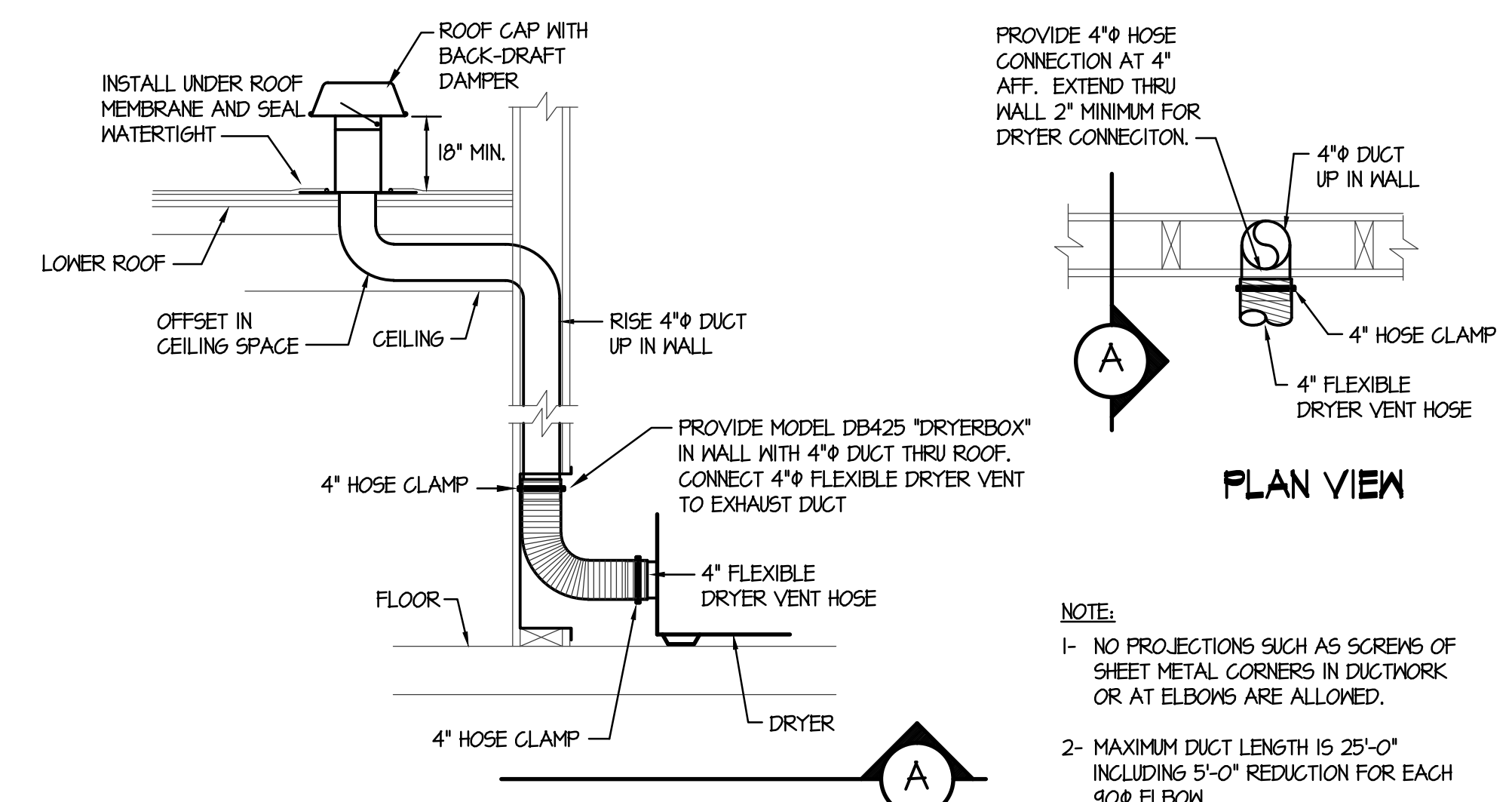

J DRYER VENT DETAIL
NO SCALE

ORIGINAL DRAWING SIGNED BY: DWAYNE C. SUDWEERS
DATE ORIGINAL SIGNED: April 15, 2018
ORIGINAL ON FILE AT ENGINEERED SYSTEMS ASSOCIATES
1355 EAST CENTER, POCATELLO, IDAHO 83201

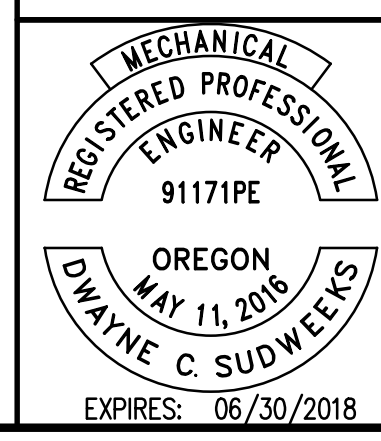

Engineered Systems Associates
1355 EAST CENTER
POCATELLO, IDAHO 83201
PHONE: (208) 233-0501
FAX: (208) 233-0529
EMAIL: esa@engsystems.com
ESA JOB NUMBER: 16038